



Headquarters >

NR Electric Co.,Ltd.

69 Suyuan Avenue, Nanjing 211102, China
Tel:+86 25 87178888 Fax:+86 25 87178999
Email: NRservices@nrec.com, NRsales@nrec.com

Subsidiaries >

NR Engineering Co., Ltd.

69 Suyuan Avenue, Nanjing 211102, China
Tel:+86 25 87178888 Fax:+86 25 87178999
Email: NRservices@nrec.com, NRsales@nrec.com

NR Electric – Hongkong Subsidiary

NR Electric International Co., Ltd.
Unit C, 7/F, Ford Glory Plaza, 37-39 Wing Hong Street,
Cheung Sha Wan Kowloon, Hong Kong
Tel: +852 23703773
Fax: +852 27439555
Email: international@nrec.com

NR Electric – Indonesia Subsidiary

PT. NR Electric Jakarta
F Square – Komplek Pergudangan Taman Tekno, F1/FB Jl
Taman Tekno Widya, BSD, Tangerang Selatan. 15314
Indonesia
Tel : +62 21 7567 2445
Email: indonesia@nrec.com

NR Electric – India Subsidiary

NR Energy Solutions India Pvt. Ltd.
Plot No. 96 & 97, Ajivali Village, Opp. Navkar Logistics, Old
Mumbai Pune Highway, Panvel – 410221 (Maharashtra)
Tel: +91-2143-239278 / 79
Email: india@nrec.com

NR Electric – United Kingdom Subsidiary

NR Electric UK Limited
Unit 10 Woodrow Business Centre, Irlam, M44 6NN, United
Kingdom
Tel: +44 (0) 1614375947; Mobile: +44 (0)7979681591
Email: uk@nrec.com

NR Electric – Ecuador Subsidiary

NREC ECUADOR S.A.
Tel: +593 989786597 (Ecuador); +86 13814085367
(China);
Email: tiansl@nrec.com

NR Electric – United States Subsidiary

NR Electric USA LLC
11 Orchard, Suite 104, Lake Forest, CA 92630
Tel: + 1 9492328154 (U.S.A); + 86 15251820737 (China);
Fax: +1 949 305 7763
Email: usa@nrec.com

NR Electric – Nigeria Subsidiary

NR Electric Nigeria Co., Ltd.
E3B, Salatu Royal Estate, Aminu Kano Crescent, Wuse II,
Abuja, Nigeria
Tel: +234 810 3881005
Email: luow@nrec.com

Sales Representative Office and Technical Service Center >

NR Electric – Kazakhstan Office

NR Electric (Kazakhstan) Representative Office & TSC
Қазақстан, астана ханов Керей и Жанибек, д.18 офис 307
Tel: +7 702 3688159
Email: cis@nrec.com

NR Electric – Philippines Office

NR Electric (Philippines) Representative Office & TSC
1408, 14 st Floor, Raffles Corporation Center, Emerald Avenue,
Brgy. San Antonio, Ortigas Center, Pasig City 1605, Philippines
Tel: + 63 2 5841533; + 63 2 5841471
Fax: + 63 2 5709511
Email: philippine@nrec.com

NR Electric – Vietnam Office

NR Electric (Viet Nam) Representative Office & TSC
5th floor, CDC Building, 25 Le Dai Hanh, Hai Ba Trung, Ha Noi,
Vietnam
Tel: +84 24 32202069
Fax: +84 24 32202069
Email: vietnam@nrec.com

NR Electric – Canada Office

NR Electric USA LLC (Canada)
Tel: +1 9492328154(Canada); +86-15251820737 (China)
Email: wangbin3@nrec.com

NR Electric – Mexico Office

NR Electric USA LLC (Mexico)
Tel: +52 1 5587634083 (Mexico); +86-13851981647 (China)
Email: mayq@nrec.com

NR Electric – Cote d'Ivoire Office

NR Electric (Cote d'Ivoire) Representative Office & TSC
Bietry Zone 4 C non loin de la pharmacie perussia à l'immeuble
NAJCO, Abidjan, Cote d'Ivoire
Tel: + 225 68126320 (Cote d'Ivoire); + 86 18013801739 (China)
Email: xiangzq@nrec.com

NR Electric – Ethiopia Office

NR Electric (Ethiopia) Representative Office & TSC
Bole Sub City in Front of Rwanda Embassy, Addis Ababa,
Ethiopia
Tel: +251 933923101
Email: Liugc@nrec.com

NR Electric – Zambia Office

NR Electric (Zambia) Representative Office & TSC
Plot NO.6953 Millennium Village (Villa 19), Longacres Lusaka,
Zambia
Tel: +260 96 9498326
Email: Yinxl@nrec.com

NR Electric – Kenya Office

NR Electric (Kenya) Representative Office & TSC
C1, Crest Park, Denis Print,Nairobi,Kenya
Tel: +254 799574669
Email: dingmw@nrec.com



VSC-HVDC TRANSMISSION TECHNOLOGY

Connecting Bulk Power to Massive Grids



NR Electric Co., Ltd.

69 Suyuan Avenue, Nanjing 211102, China
Tel +86 25 8717 8888 Fax +86 25 8717 8999
NRservices@nrec.com / NRsales@nrec.com

NR Electric Co., Ltd.





Contents

What HVDC can do	01
All in one service package to maximize your benefits	03
World-Class Test Labs to Ensure the Performance	04
Case Study	05

What HVDC can do

Field proven HVDC technology makes grid more resilient

HVDC is a well proven technology designed for long distance bulk power transmission, asynchronous grids interconnection and etc. It delivers more power over long distance with less right-of-way and fewer overhead lines or cables.

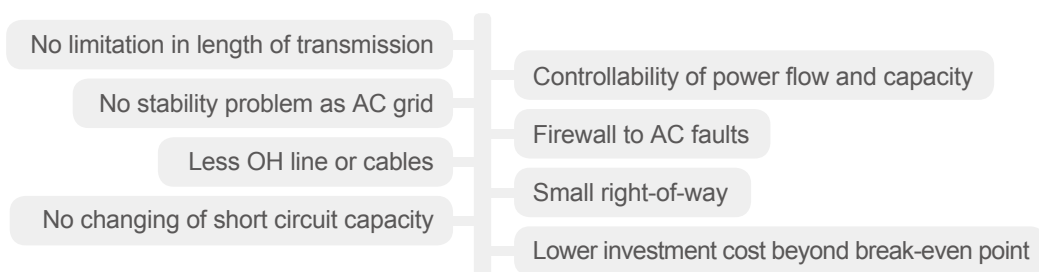

Advantages of HVDC

Currently, there are two main HVDC technologies, Line Commutated Converter (LCC) HVDC and Voltage Sourced Converter (VSC) HVDC. LCC-HVDC system is mostly employed for long distance bulk power transmission. The latest HVDC technology applied advanced IGBT module has technical advantages and more application fields consequently.

Until 2018, NR Electric has provided its state of the art HVDC solution to 23 LCC-HVDC projects and 6 VSC-HVDC projects. Based on its strong technical background and vast experience over HVDC, NR Electric provides reliable LCC-HVDC and VSC-HVDC solutions to our clients worldwide.

Satisfying your expected technical requisites

The critical difference between LCC-HVDC and VSC-HVDC is semiconductor of converter, the VSC-HVDC applies IGBT which is a fully-controlled power electronic device. This leads to many distinct differences between LCC-HVDC and VSC-HVDC:

LCC HVDC	VSC HVDC
Line Voltage Commutated	Self-Commutated
Controllability of active power only	Controllability of both active and reactive power
Large footprint	Small footprint
No black start function	Black start function
Inconvenience for multi-terminal	Convenience for multi-terminal

Comparison between LCC and VSC HVDC



Grid Interconnection / Energy Market

- Compatible for rigid and flexible grid.
- Increase power quality and system stability.
- Quick capacity control.
- Bi-directional power flow.
- Isolation of disturbances and fault in HV AC grids.
- Black start function.
- Available for Multi-terminal systems.

Power Supply to Islands

- No transmission length limitation.
- Enhancement of power quality and stability.
- Renewable power access to grid

Decoupling of Urban Grid

- Connecting AC grids without increasing the short circuit capacity.
- Reactive power compensation to grid.

City Centre In-Feed

- Decrease rights-of-ways and cable expense.
- More power transfer capability.
- Small footprint of converter station.
- Power quality enhancement.

Off Shore Wind Farm

- Regulation of system voltage and frequency.
- No transmission length limitation.
- Convenient mobile operation of off-shore converter.
- High power quality.
- Simplified platform with compact construction.

Power from Shore

- Decent economic benefits.
 - Less maintenance and operation expense.
 - Less carbon tax credits.
 - Gas earning for power generation is more than electricity bill.
- Least risk of fire and explosion.
- Better work environment with less noise and vibration.

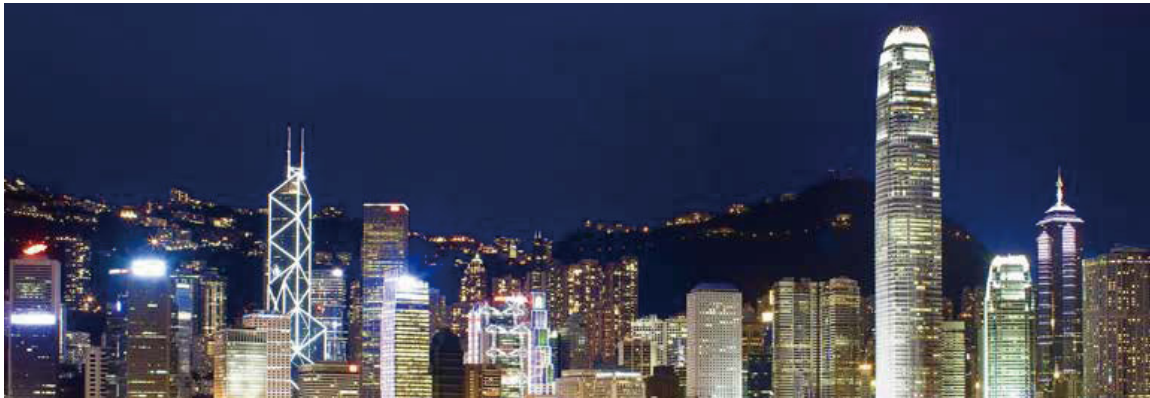

All in one service package to maximize your benefits

Experienced capability of system design & analysis

NR Electric focuses on electric power system solution for decades and is the top expert in the field of power electronics and HVDC. NR Electric has got various achievements across system study and analysis. For HVDC system, NR Electric is competent for main circuit study, operation modes study, overvoltage & insulation coordination design, transient current simulation & analysis, main equipment design, protection and control scheme design, grounding schemes design and etc.

Station engineering expertise

NR Electric has its own dedicated station engineering team which is fully compliant with IEEE 1031. Meanwhile, NR Electric corporates with its design partner closely to implement co-design.

Exceptional manufacturing techniques

NR Electric is equipped with world-class producing and testing facilities which makes NR top level manufacturer of HVDC converter, DC breaker, control and protection system and DC measurement equipment. For the VSC valve is up to ± 800 kV and for LCC ± 1100 kV.

NR Electric' s ± 535 kV/3000MW VSC converter has got type tests verification by DNV GL in 2017 which is fully compliance with IEC 62501. The 535kV DC breaker has also got type tests verification by DNV GL in 2017.



± 535 kV/3000MW converter tower



± 535 kV DC breaker

World-Class Test Labs to Ensure the Performance

NR Electric possesses certificated test labs, including RTDS and RT-LAB lab, dynamic lab, HV lab and BTB VSC-HVDC test platform. These are managed by specialized engineering team.



VSC-HVDC BTB test platform

Global supply chain

NR Electric constantly improving the global development of its supply chain teams, leveraging supply chain management processes, tools and systems across the function. A network of innovative and excellent suppliers assist us to create lasting value within procurement.

Professional project management team and local partners

NR Electric has a holistic approach to Project Management, where each stage or element of the project is carefully broken down, assessed and re-constructed to ensure maximum success of the project. This could be in terms of programme efficiency; design control; quality control; risk management; site installation; commissioning and most importantly safety throughout the project. To implement this methodology, NR Electric utilizes a suite of documentation to provide a robust process that is simple to follow and effects the necessary audit trail. NR Electric is willing to cooperate with strong local partners for smooth project execution and localization.

Service & support experts

NR Electric has a sophisticated service and support experts team that 70% of them have more than 5 years' HVDC site commissioning and trouble-shooting experience. They possess both theoretical knowledge and practical experience. They are professional in all stages of VSC-HVDC.

Operation & maintenance (O&M)

NR Electric operation and maintenance (O&M) services covers all activities and aspects necessary to run your HVDC system in a most economical and safe manner. O&M helps the customer to minimize the risk, improved efficiency and increased productivity.

Training

NR Electric could provide clients comprehensive training courses, it could be factory training, onsite training or tailor-made training.

Case Study

±500kV Zhangbei DC grid, China

Zhangbei VSC-HVDC grid is a 4 terminal DC grid with ±500kV DC voltage rating, with each terminal rated as 3000MW/3000MW/1500MW/1500MW. Zhangbei area and Kangbao area are the bases for renewable generation, these renewable power is transmitted to load center-Beijing. While Fengning will act as a pump storage plant to counteract intermittence of renewables.



Rated DC voltage	±500kV
Rated power	3000MW/3000MW/1500MW/1500MW
Topology	Bipolar
Converter technology	MMC
Type of construction	Overhead transmission lines

Basic Information of Zhangbei DC Grid

Considering highly fluctuation voltage of wind and solar power, when a high volume of green energy connects to weak AC grid directly, may result in a very unstable grid-connection for renewable sources. For the purpose of solving the challenges above, VSC-HVDC became the best option.

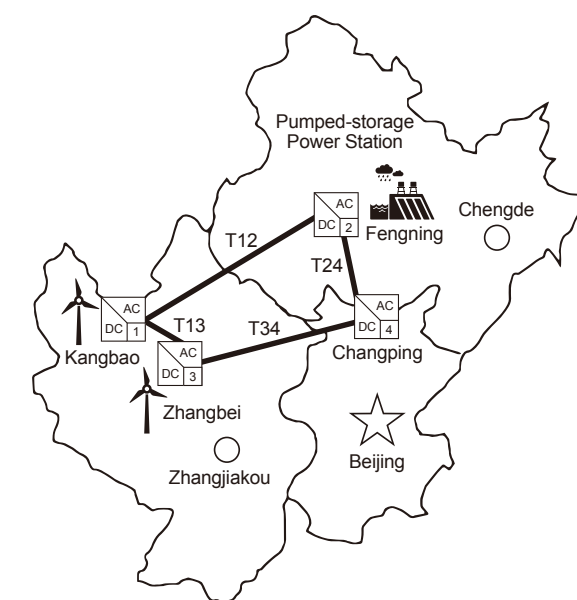

System schematic diagram



Breakthrough solutions for DC grid technology

It will also install unique equipment-DC breaker because it's a DC grid with overhead transmission lines, half bridge topology + DC breaker are applied to clear DC faults. This is the first time that DC breakers are installed in commercial VSC-HVDC link, it is a big milestone for VSC-HVDC development.

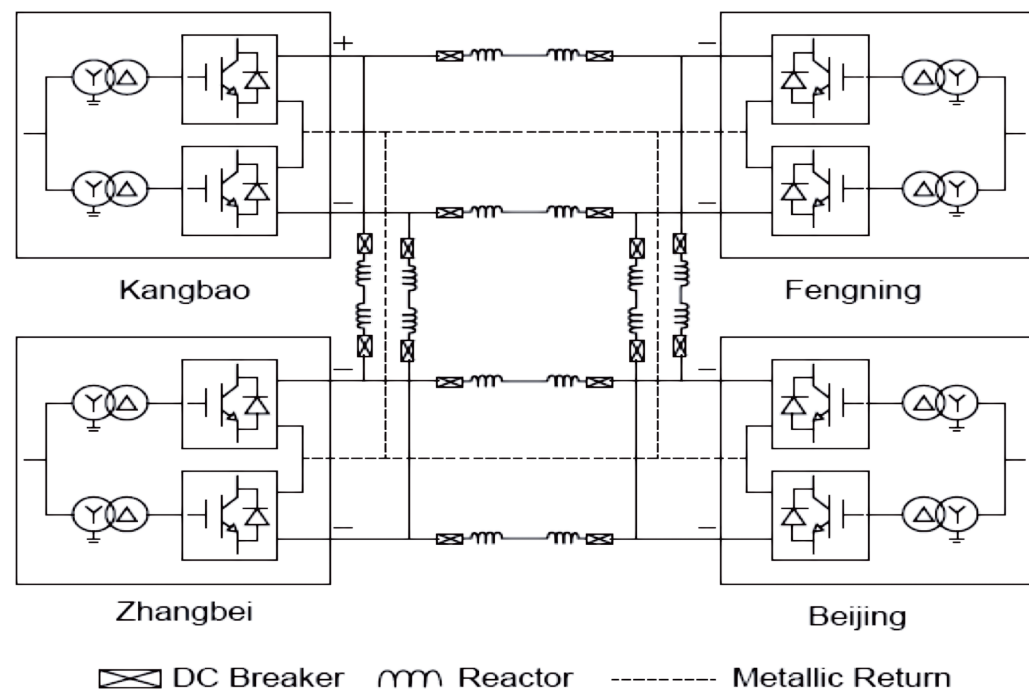

4 terminal VSC-MTDC Circuit Diagram



NR Electric provides its state of art equipment & sophisticated management and technical team to Zhangbei DC grid. Equipment provided by NR includes protection & control system, Converter valves, DC breakers and measurement devices.

Benefits

- DC Grid will become a stable and efficient renewable energy transmission channel.
- Zhangbei VSC-HVDC project can provide 26TWh of green electricity to Beijing and adjacent area.
- It will also supply clean electricity for the 2022 Beijing winter Olympics, achieving the goal of "green Olympics".